

# Big Data Camp Panel

---

- Pete Aceves, *U of Chicago - Sociology*
- Cassandra Chambers, *Management and Organizations*
- Teddy DeWitt, *Management and Organizations*
- Ronnie Lee, *Strategy*
- Jeff Lockhart, *Sociology and Population Studies*

Pete Aceves

U of Chicago - Sociology

# Creatively using computational tools for theoretical development

Most computational tools are created by

- **Computer scientists**
  - International World Wide Web Conference
  - Association for the Advancement of Artificial Intelligence (AAAI)
  - Association for Computing Machinery's (ACM) Special Interest Groups (SIG) Knowledge Discovery in Data
- **Computational linguists**
  - Association of Computational Linguistics
  - Empirical Methods in Natural Language Processing

But creatively using these tools is up to you

# Examples

What is the information density of each language?

- Huffman encoding

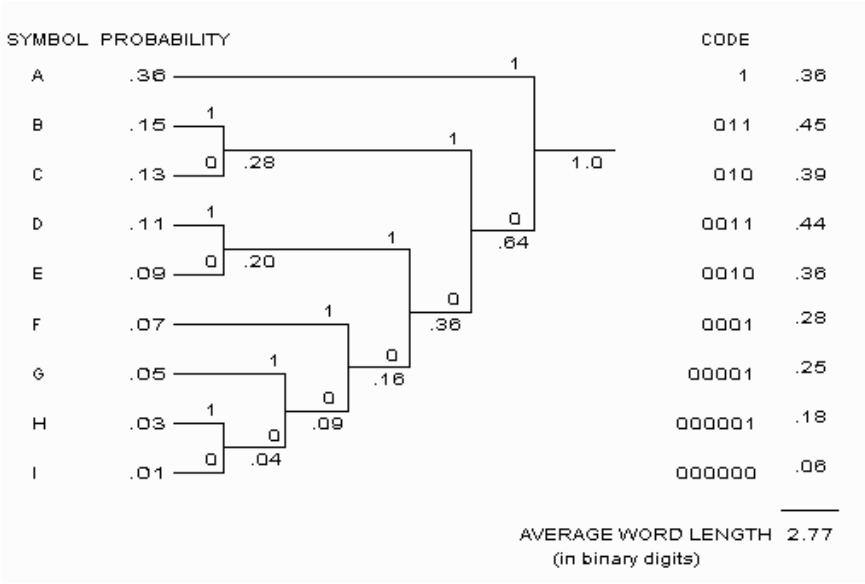

How can we quantify the theoretical integration of subfields within physics?

- Two-layer neural network of all papers published in the American Physical Society journals (using gensim's word2vec implementation)

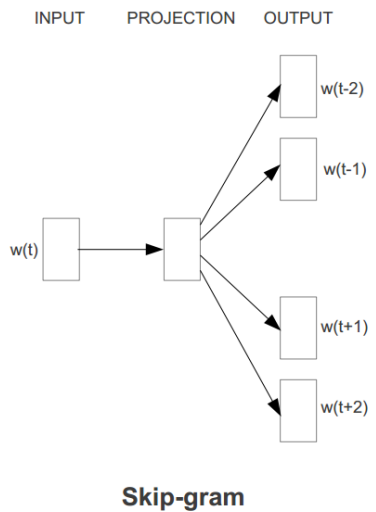
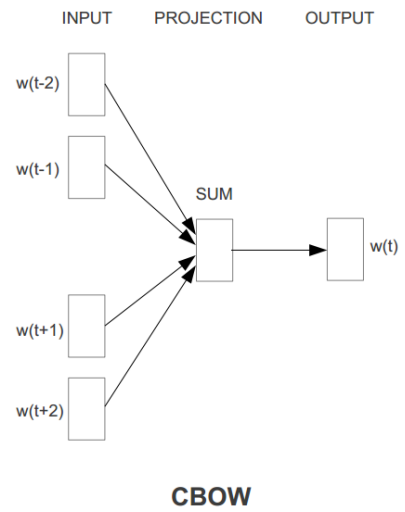

# Cassandra Chambers

Management and Organizations

# Convert Stata .dta file to CSV without Stata software

Ask Question



asked 7 years, 1 month ago  
viewed 68424 times  
active 1 year, 1 month ago

#Times Question is Upvoted

#Times Question Selected as a Favorite

Comments

Question tags (often searched for by answerers)

Profile of Last question editor

Profile of Question Poster

Poster's Current Reputation

Poster's current badges (not tied to site privileges)

▲ 41 Is there a way to convert a dta file to a CSV?

▼ 12 I don't have a version of Stata so I can't do something like save as CSV file.

csv stata file-conversion

share improve this question

edited Sep 15 '14 at 14:26 LondonRob 16.6k ● 7 ● 39 ● 79

asked Mar 29 '10 at 6:03 Brian 7,979 ● 39 ● 111 ● 153

1 I'm sure there is a way. If the format of the .DTA file is specified, it can become a simple programming exercise – Eli Bendersky Mar 29 '10 at 6:07

1 it's binary, I'm not sure how to get it out of there – Brian Mar 29 '10 at 6:12

add a comment

8 Answers

active oldest votes

BLOG

Stack Overflow en Español has Graduated!

## Optimizing Amazon Redshift

A Real World Guide

Get the Free eBook

MATILLION

<?xml version="1.0" encoding="UTF-8"?>

- <posthistory>

<row Text="I have been singing in a (classical) choir for several years, including the occasional solo line, and am now seriously considering voice lessons. However, finding a good teacher seems like a daunting challenge. What should I look for in a good voice teacher?" UserId="9" CreationDate="2011-04-26T18:54:45.590" RevisionGUID="2e3d0192-2d52-44f9-b11e-79c28769c576" PostId="1" PostHistoryTypeId="2" Id="1"/>

<row Text="Criteria for selecting a voice teacher" UserId="9" CreationDate="2011-04-26T18:54:45.590" RevisionGUID="2e3d0192-2d52-44f9-b11e-79c28769c576" PostId="1" PostHistoryTypeId="1" Id="2"/>

<row Text="<voice><pedagogy><lessons>" UserId="9" CreationDate="2011-04-26T18:54:45.590" RevisionGUID="2e3d0192-2d52-44f9-b11e-79c28769c576" PostId="1" PostHistoryTypeId="3" Id="3"/>

<row Text="I've heard it said that, whilst on most instruments these notes are played with the same fingerings/technique/etc there is a subtle difference. This isn't specific to this particular note combination, but to all enharmonic equivalents. What might this teacher have been referring to?" UserId="11" CreationDate="2011-04-26T18:59:07.007" RevisionGUID="9db25e69-0cdf-478d-893b-19a240deffa5" PostId="2" PostHistoryTypeId="2" Id="4"/>

<row Text="What's the difference between a Gb and an F#?" UserId="11" CreationDate="2011-04-26T18:59:07.007" RevisionGUID="9db25e69-0cdf-478d-893b-19a240deffa5" PostId="2" PostHistoryTypeId="1" Id="5"/>

<row Text="<theory><enharmonic-equivalent><key-signature>" UserId="11" CreationDate="2011-04-26T18:59:07.007" RevisionGUID="9db25e69-0cdf-478d-893b-19a240deffa5" PostId="2" PostHistoryTypeId="3" Id="6"/>

<row Text="Oftentimes major keys are called "happy" and minor keys are "sad". Why is this? Is it universal across cultures that use these scales? What about in other scale systems – do similar connotations exist?" UserId="23" CreationDate="2011-04-26T19:00:35.140" RevisionGUID="be56be4a-75bc-4239-be4a-cf1c6296ccb2" PostId="3" PostHistoryTypeId="2" Id="7"/>

<row Text="Why are minor keys universally accepted to sound "sad"?" UserId="23" CreationDate="2011-04-26T19:00:35.140" RevisionGUID="be56be4a-75bc-4239-be4a-cf1c6296ccb2" PostId="3" PostHistoryTypeId="1" Id="8"/>

<row Text="<keys>" UserId="23" CreationDate="2011-04-26T19:00:35.140" RevisionGUID="be56be4a-75bc-4239-be4a-cf1c6296ccb2" PostId="3" PostHistoryTypeId="3" Id="9"/>

<row Text="Consider four cases: - A-Flat Major - A-Flat minor: natural, melodic, and harmonic I start them with the third finger on the A-flat key (both hands), but I have no idea how a professional pianist would do it. Help!" UserId="18" CreationDate="2011-04-26T19:00:53.253" RevisionGUID="0cd10f77-e37a-452e-bb9c-b75d128682eb" PostId="4" PostHistoryTypeId="2" Id="10"/>

**Macro Phenomenon:** Incentive Systems to promote cooperation

You earn reputation when people vote on your posts

Your reputation score goes up when others vote up your questions, answers and edits.

As you earn reputation, you'll unlock new privileges like the ability to vote, comment, and even edit other people's posts.

At the highest levels, you'll have access to special moderation tools. You'll be able to work alongside our community moderators to keep the site focused and helpful.

(4)

**Macro-level association**

**Macro Outcome:** System Survives / Thrives

**An "Ecosystem of Mechanisms" from my dissertation**

**Situational Mechanism (1):** Being ranked for contributions creates feelings of competitiveness

What can we do against strategic downvotes? [closed]

Sometimes a downvote comes just with an excuse from a person who answered to the same question. I don't want to make a specific example, neither to accuse a specific person, so I'll make an example.

- A: answers the question, there are syntax errors on his questions;
- People make him notice the syntax errors and A: edits the answer;
- B: answers to the question, everything is OK with his answer;
- B: makes A: notice that he is returning an area of memory which is on the stack, so the code isn't correct, and he downvotes;
- A edits the answer, but downvotes B: too, with an excuse like that he is casting the result of a2a2c; and that this cast is useless.

So in this case we can't demonstrate that A: downvotes to B: just with an excuse, since there is an apparent reason to his downvote. But if usually A: downvotes for big errors, then he now downvotes for a small error, or for a non-error, a matter of personal taste like casting or not casting the result of malloc. He wouldn't do the same if the answer wasn't competing with him, but no one can demonstrate this.

Now -2 points are nothing, but this can happen several times. It may also happen that a user downvotes for wrong reasons, so how do we demonstrate that we are right in that case? Is there a way to debate on the downvote even though -2 points are nothing? The reason is mainly to be politically correct, not because I care about losing few points.

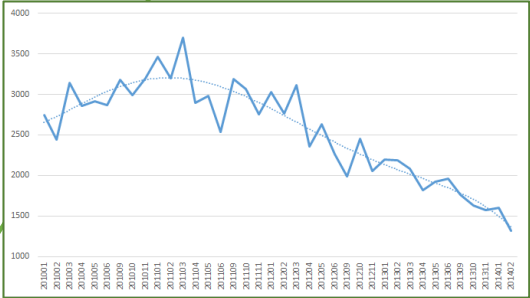

**Transformational Mechanism (3):** Aggregation & transmission of uncooperative behaviors leads to lower rates of cooperation over time

**Action-Formation Mechanisms (2):**

- Feelings of Competitiveness are associated with uncooperative behavior (e.g., a drive to “game the system”)
- Being systematically “unrecognized for your work” decreases your tendency to cooperate

Source: Stack Exchange



Teddy DeWitt

Management and Organizations

Ronnie Lee

Strategy

Jeff Lockhart

Sociology and Population Studies